



Operation Manual of Outdoor High-Speed Pan/Tilt



V 1.3

You are pleased to read the manual carefully before using the product.

Sign of Safety

	ATTENTION Please Do Not Open to Avoid Electrical Shock!	
<p>Attention: Please do not dismount it by yourself to avoid electrical shock. There is no part inside, which needs customer to repair it. All repair work should be carried out by eligible person.</p>		



The flashing arrow in the upward triangle is used to remind customer that there is larger “non-insulated dangerous voltage” exists near the product, which can cause danger upon human body.



The notice mark in the upward triangle is used to remind customer to refer to important operation and instructions of maintenance of the product.

The manufacture no. of the machine is marked on the bottom or on the side. Please fill out the manufacture no. on the blank below and keep the operation manual well for reference if needed.

Model: _____

Manufacture No. _____

CONTENTS

I	Points for Attention	1
II	Introduction of Functions	2
III	Quick Guide of Installation	3
	1. Modify the Protocol and the Address	3
	2. RS485 Terminal Resistor	5
	3. Sizes	6
	4. Wall Mounting	6
	5. Base Plate Mounting	9
	6. Connection	10
IV	Description of Functions of the Menu	12
	1. Basic Operation of the Menu	12
	2. Setup of the Menu	12
	3. Appendix of the Menu	14
V	Special Operation	16
VI	Technical Data	17

I Notes for Attention

1. Read the manual carefully before installing the product.
2. Power Supply: 220V/110V/24V, refer to the sticker on the product.
3. There are sophisticated optical and electronic components inside the product. Avoid incorrect operation methods such as heavy pressing or strong vibration during the course of transportation, store and installation otherwise the product could be damaged.
4. Please do not dismount components inside the product to avoid occurrence of trouble. There is no part inside the product, which needs repair by customer himself.
5. Observe all electric safety standard in application and adopt special power supply attached the product. RS-485 and video signal should keep enough distance with the high voltage devices and cable during the course of transmission, and take protection measures such as anti-lightning and surging etc. id necessary.
6. Do not apply the product under the state which exceeds limited temperature, humidity or specifications of power supply.
7. Do not aim the camera at the sun or very bright object, or to monitor bright and still object whether the power supply is switched on or off.
8. Do not clean the product with strong or abrasive detergent. Clean out dirt with dry cloth or mild detergent if dirt is not easily removed.
9. Take care to apply the product to avoid collision or vibration. Improper application can cause damage.
10. Install the product on the place where it has enough supportability.
11. Wipe dust on the lens with special lens paper.

II Introduction of Functions

1. Unlimited rotation 360° horizontally and from +33° to -80° vertically.
2. The horizontal speed is 0 - 40°/sec while the vertical speed is 0 - 20°/sec (wind speed less than 50 miles/hour).
3. At the preset position, the horizontal speed is 0 - 100°/sec while the vertical speed is 0 - 40°/sec (wind speed less than 50 miles/hour).
4. Automatic control of constant temperature, manual rain wiper/defroster control.
5. IP grade IP66.
6. The bearable maximum wind speed is 130 miles/hour.
7. 128 preset positions in memory and 6 groups of programmable patrol loci, as well as linear scan between two points with adjustable speed and variable direction,
8. 16 common protocols integrated, four kinds of baud rate 2400/4800/9600/19200 bps available and 1024 addresses are supported (0 - 1023).

III Quick Guide of Installation

1. Modify the Protocol and the Address (jump over this section if no modification)

Take out the small metal cover on the bottom shown as dotted-lined part on Figure 3.1.1 to expose DIP switch of the address and the protocol shown as Figure 3.1.2. The detailed drawing is shown as in Figure 3.1.1.

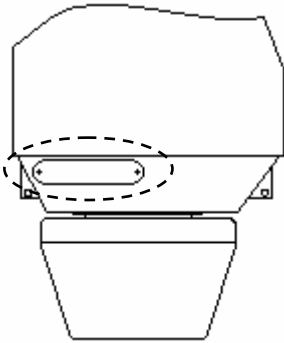

Figure 3.1.1

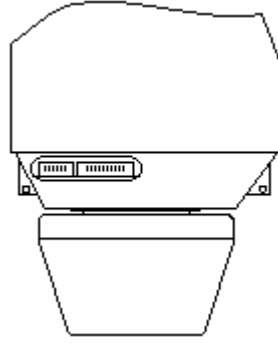

Figure 3.1.2

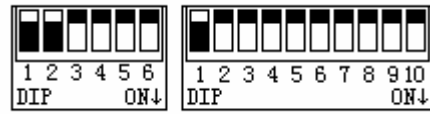

Figure 3.1.3

Shown as Figure 3.1.3, the 10-bit DIP stands for the addresses which can be from 0 to 1023. The 6-bit DIP stands for the protocols in which bits 1-4 mean the protocol while bits 5-6 means the baud rate. Push the DIP downward means ON otherwise it means OFF. For example the address in the figure means 1 while the protocol means PELCO-D with the baud rate of 2400bps which can be found from the table.

Address of PT	Status of DIP Switch									
	DIP-1	DIP-2	DIP-3	DIP-4	DIP-5	DIP-6	DIP-7	DIP-8	DIP-9	DIP-10
1	ON	OFF	OFF	OFF	OFF	OFF	OFF	OFF	OFF	OFF
2	OFF	ON	OFF	OFF	OFF	OFF	OFF	OFF	OFF	OFF
3	ON	ON	OFF	OFF	OFF	OFF	OFF	OFF	OFF	OFF
4	OFF	OFF	ON	OFF	OFF	OFF	OFF	OFF	OFF	OFF
5	ON	OFF	ON	OFF	OFF	OFF	OFF	OFF	OFF	OFF
6	OFF	ON	ON	OFF	OFF	OFF	OFF	OFF	OFF	OFF
7	ON	ON	ON	OFF	OFF	OFF	OFF	OFF	OFF	OFF
8	OFF	OFF	OFF	ON	OFF	OFF	OFF	OFF	OFF	OFF
9	ON	OFF	OFF	ON	OFF	OFF	OFF	OFF	OFF	OFF
10	OFF	ON	OFF	ON	OFF	OFF	OFF	OFF	OFF	OFF
11	ON	ON	OFF	ON	OFF	OFF	OFF	OFF	OFF	OFF
12	OFF	OFF	ON	ON	OFF	OFF	OFF	OFF	OFF	OFF
13	ON	OFF	ON	ON	OFF	OFF	OFF	OFF	OFF	OFF
14	OFF	ON	ON	ON	OFF	OFF	OFF	OFF	OFF	OFF
15	ON	ON	ON	ON	OFF	OFF	OFF	OFF	OFF	OFF

16	OFF	OFF	OFF	OFF	ON	OFF	OFF	OFF	OFF	OFF
17	ON	OFF	OFF	OFF	ON	OFF	OFF	OFF	OFF	OFF
18	OFF	ON	OFF	OFF	ON	OFF	OFF	OFF	OFF	OFF
...
1023	ON	ON	ON	ON	ON	ON	ON	ON	ON	ON

Table 1 Table of Addresses in DIP Switch

Examples:



Type of Protocols	Selection of Communication Protocols				Common Baud Rates	
	DIP-1	DIP-2	DIP-3	DIP-4	DIP-5	DIP-6
SAMSUNG	ON	OFF	OFF	OFF	OFF	ON
B01	ON	OFF	OFF	OFF	OFF	ON
NEON	ON	OFF	OFF	OFF	OFF	ON
Santachi	OFF	ON	OFF	OFF	OFF	ON
PELCO-D	ON	ON	OFF	OFF	OFF	OFF
PELCO-P/4800	OFF	OFF	ON	OFF	ON	OFF
PELCO-P/9600					OFF	ON
PANASONIC	ON	OFF	ON	OFF	OFF	ON
Longcomity	OFF	ON	ON	OFF	OFF	ON
HUNDA600	ON	ON	ON	OFF	OFF	ON
LILIN	OFF	OFF	OFF	ON	OFF	ON
VICON	ON	OFF	OFF	ON	ON	OFF
MOLYNX	OFF	ON	OFF	ON	OFF	ON
KALATEL	ON	ON	OFF	ON	ON	OFF
VCL	OFF	OFF	ON	ON	OFF	ON
Reserved	ON	OFF	ON	ON	OFF	ON
ALEC	OFF	ON	ON	ON	OFF	ON
Ultrak	ON	ON	ON	ON	OFF	ON

Table 2 Table of Protocols in DIP Switch

Some protocols and their common baud rates in DIP switch are as follows:

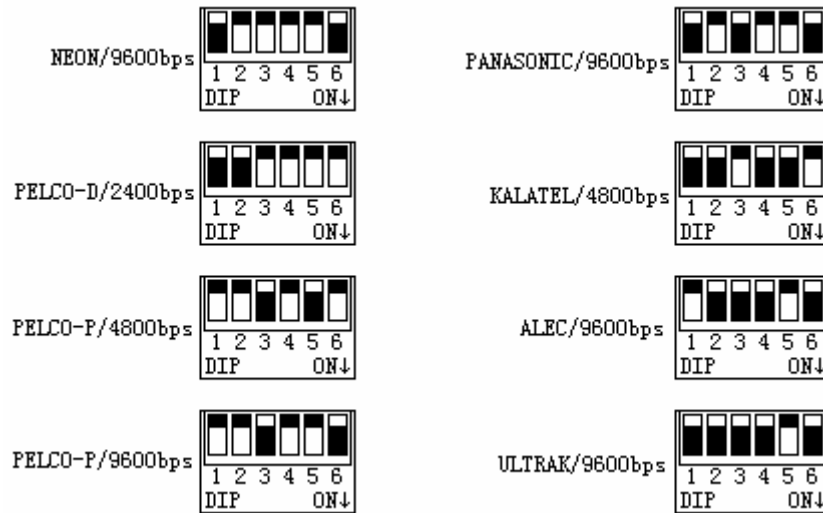

Baud Rates of Communication	Setup of Baud Rates					
	DIP-1	DIP-2	DIP-3	DIP-4	DIP-5	DIP-6
2400 bps	-	-	-	-	OFF	OFF
4800 bps	-	-	-	-	ON	OFF
9600 bps	-	-	-	-	OFF	ON
19200 bps	-	-	-	-	ON	ON

Table 3 Table of Baud Rates

2. RS485 Terminal Resistor (jump over this section if no modification)

View inward from the small hole on the bottom shown as in Figure 3.2.1, you can find a 4-bit DIP whose No.1 is the switch of the terminal resistor 120 Ω, shown as in Figure 3.2.2. Set No.1 of DIP at ON, then between Line A and Line B on 485 bus there is a terminal resistor 120 Ω connected. The default setup is at OFF which means the terminal resistor is opened.

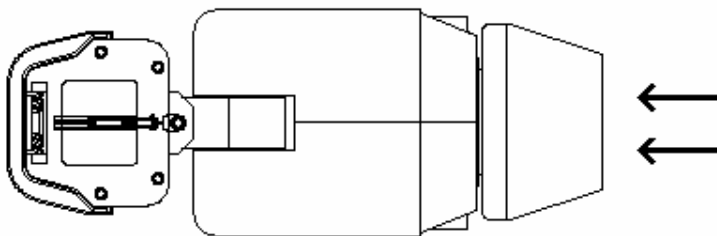

Figure 3.2.1

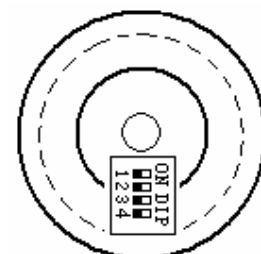
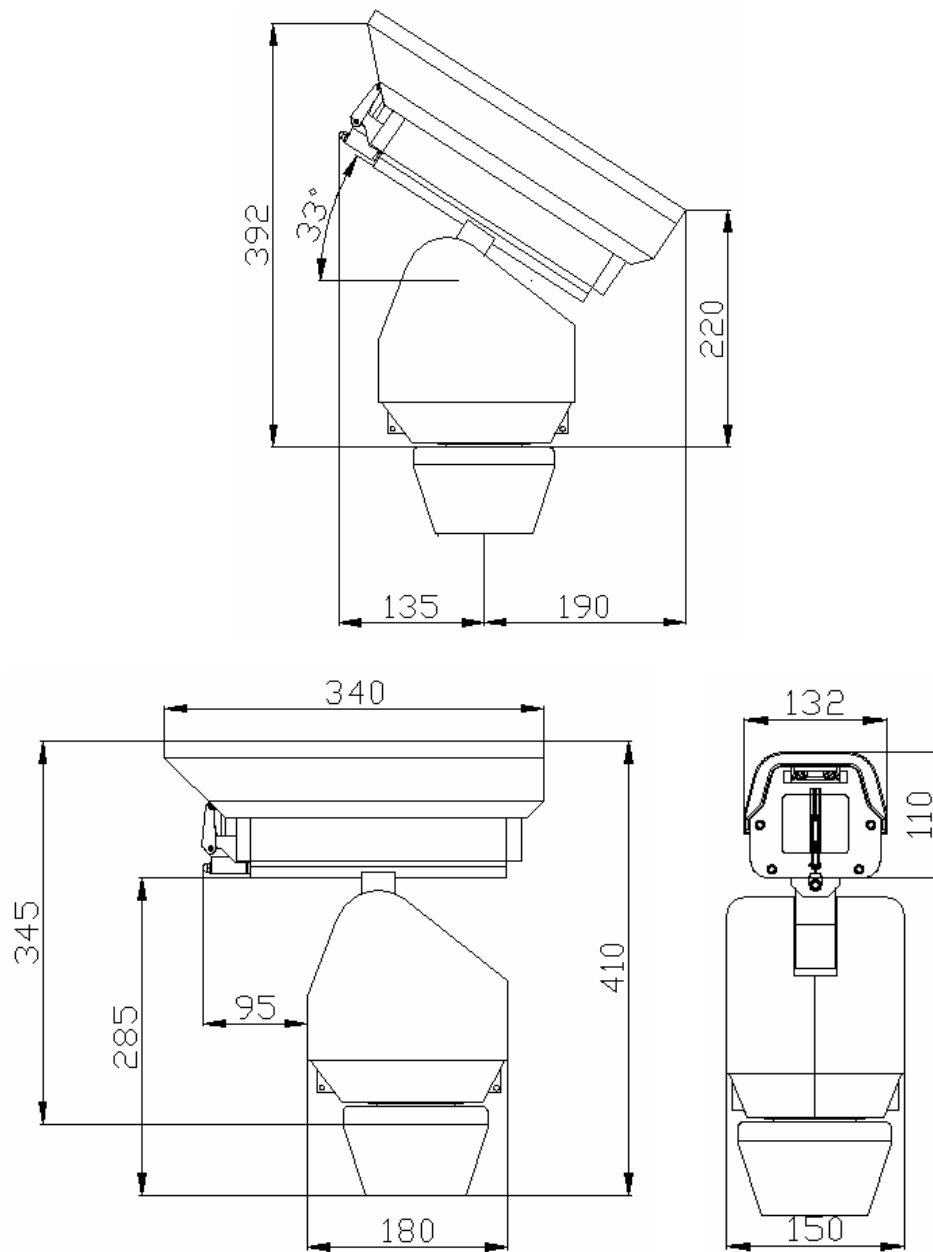

Figure 3.3.2

3. Sizes



4. Wall Mounting

The first step is to mount the bracket on the wall which is shown as in Figure 3.4.1. Figure 3.4.2 is the drawing of sizes of mounting holes.

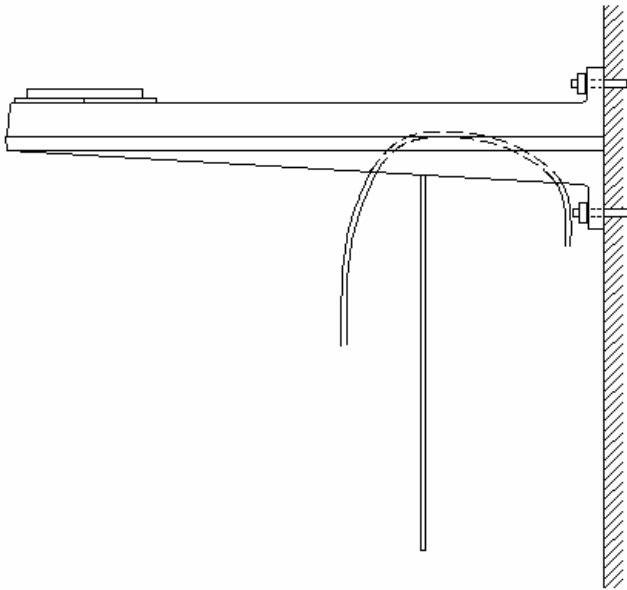

Figure 3.4.1

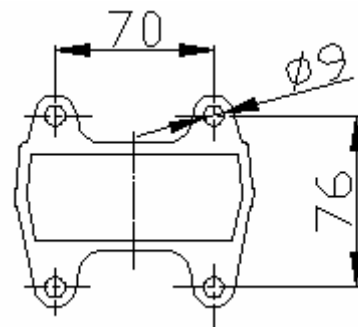

Figure 3.4.2

It is suggested to mount the support with M8 screw.

There is a mobile plate under the support. It can be laid down if screws on the front are taken off. Lead wires of the system into the support for connection.

The second step is to put the pan/tilt on the support and tighten screws upward beneath the support, shown as in Figure 3.4.3.

Please take M6×20 screw.

The third step is to connect output wires of the pan/tilt and the system, wrap the joints by insulation tape and fix the mobile plate under the support.

It should be like what Figure 3.4.4 shows.

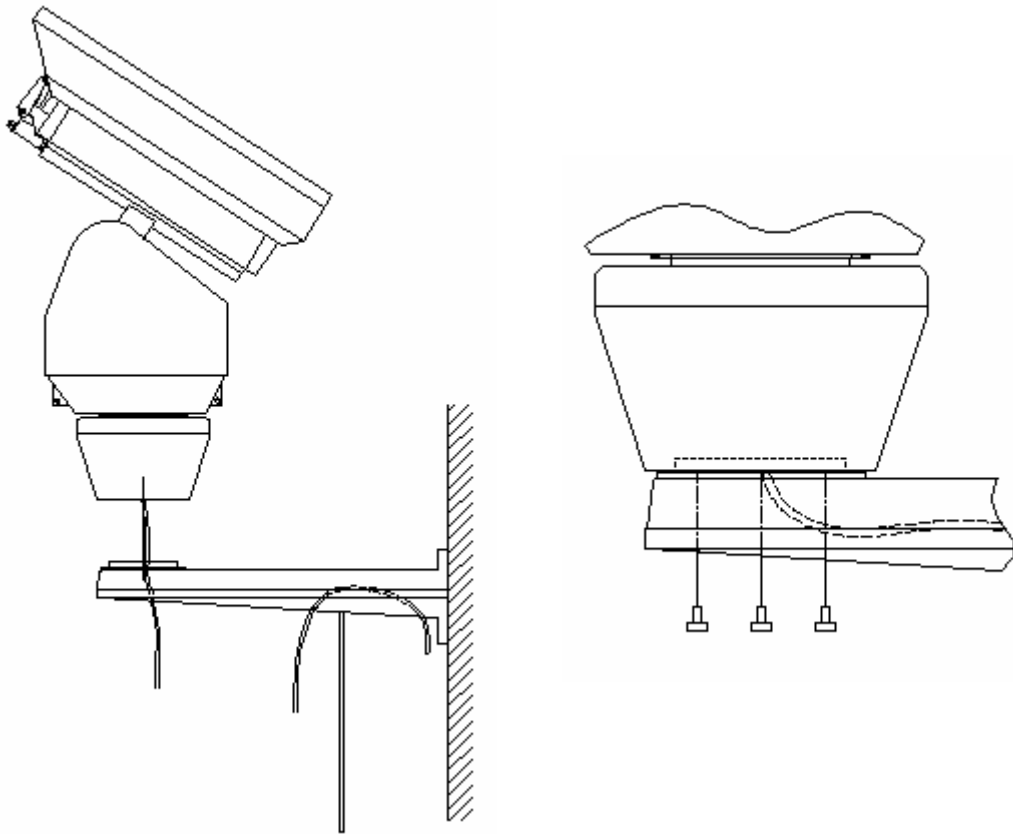

Figure 3.4.3

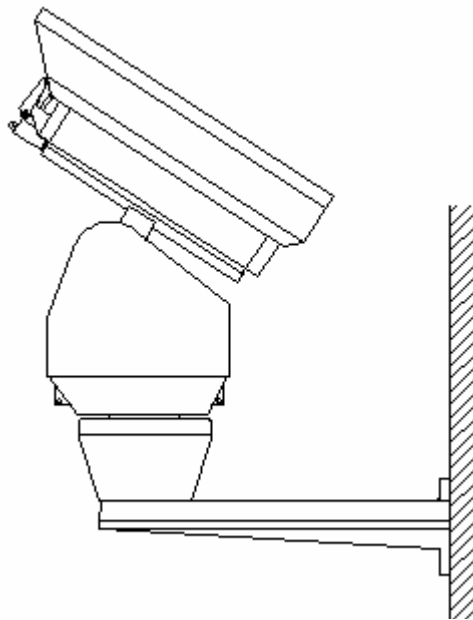

Figure 3.4.4

5. Base Plate Mounting

The first step is to drill holes on the ground referring to the positions of holes on the mounting plate. The sizes of holes are shown as in Figure 3.5.1.

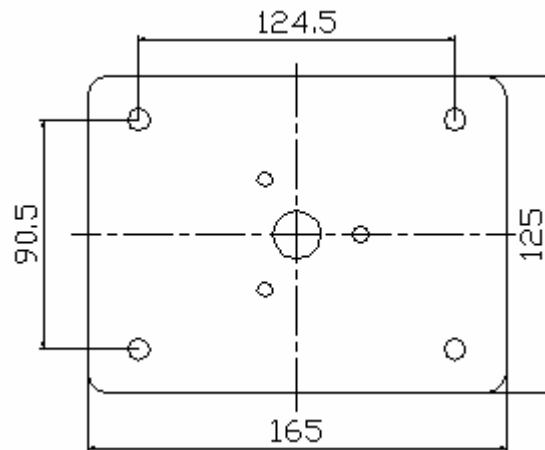

Figure 3.5.1

The second step is to fix the mounting plate on the bottom of the pan/tilt by M6×20 screw.

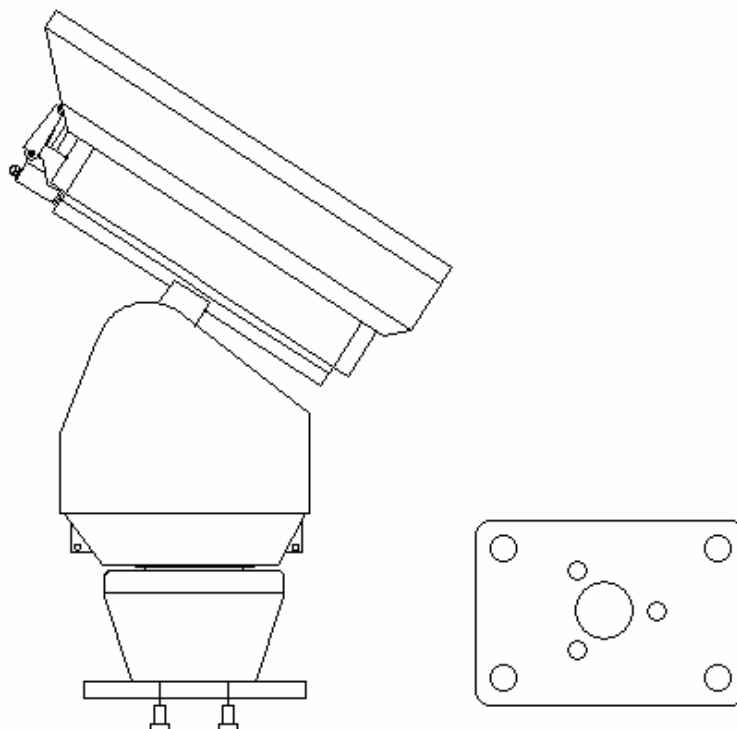

Figure 3.5.2

The third step is to fix the mounting plate with the pan/tilt on the ground. Take care that wires should be put into the groove under the mounting plate to avoid to be pressed. It is shown as Figure 3.5.3.

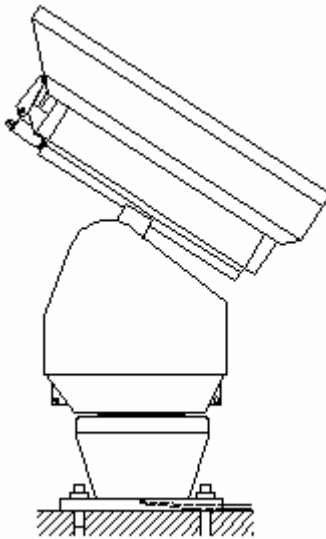
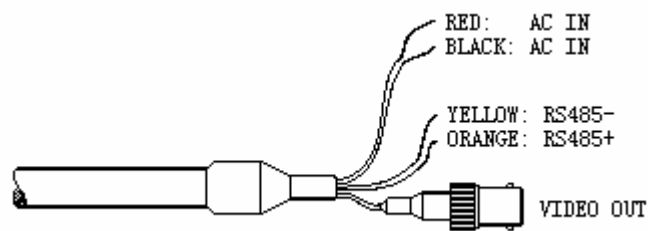

Figure 3.5.3

6. Connections

Please refer to the descriptions of following drawing.

1) System Wires



RED	Input of AC Power Supply
BLACK	Input of AC Power Supply
YELLOW	Control Wire RS485- (B)
ORANGE	Control Wire RS485+ (A)
VIDEO OUT	Video Output

2) Alarm Wires

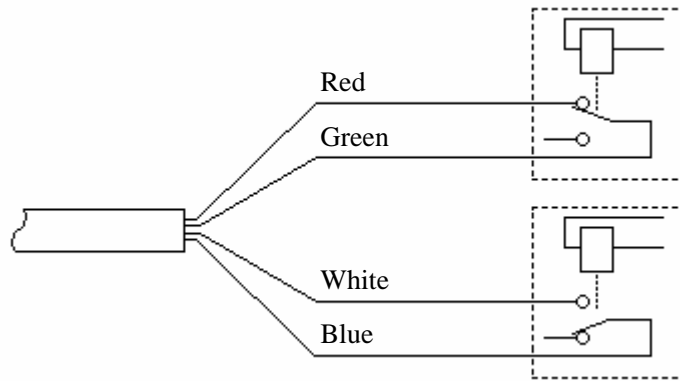

Red	Alarm Input 1
Yellow	Alarm Input 1
Green, Blue	Alarm Common Terminal

- ⚠ The alarm input should be switch signal otherwise internal circuit shall be damaged.
- ⚠ The alarm shall be linked with the presser point, which should be set in the menu. In case two channels have alarm signals simultaneously, the pan/tilt shall response upon two channels one by one with the time interval of 2 seconds.
- ⚠ In case the alarm signal is inputted, the PT shall have no response upon functions such as “AUTO PAN”, “Patrol” and “Pattern” and so on.

IV Description of Functions of the Menu

1. Basic Operations on the Menu

Open the main menu by the control keyboard or the matrix via the instruction of “Call Preset 64”. In addition the main menu can be also opened by “Call Preset 1” twice within 4 seconds.

When the menu is displayed on the screen, operate “TILT UP”, “TILT DOWN” to move the cursor to the options to be set up, and operate “PAN LEFT”, “PAN RIGHT” to modify the content or the instruction to enter into this option.

The operation can be accelerated in case the joystick is pushed towards one direction for more than 1 second.

All setups of the menu shall not be lost even after power failure.

The application under special cases can be seen in the instruction of functions of the menu.

2. Setup of the Menu

2.1 Main Menu

DISPLAY SETUP: Enter into the submenu to setup display on the screen, such as ID DISPLAY, TITLE DISPLAY and CAMERA DISPLAY.

CAMERA SETUP: Enter into the submenu of normal data of the camera.

CONTROL SETUP: Enter into the submenu of the control data of the PT.

PROGRAM: Enter into the submenu to setup enhanced function of the PT.

CAM DEFAULT SET: Restore camera default settings.

RESET PT: Reset of the PT.

EXIT: Exit the main menu.

MAIN MENU	
1.	DISPLAY SETUP
2.	CAMERA SETUP
3.	CONTROL SETUP
4.	PROGRAM
5.	CAM DEFAULT SET
6.	RESET PT
7.	EXIT

2.2 Display Setup

ID DISPLAY: When this option is set at ON, the monitor shall display the address of the camera such as “CAM 001”.

ID POS: To set up the display location of the address, which can be displayed at TOP-L (top left), TOP-R (top right), BOTT-R (bottom right) and BOTT-L (bottom left).

TITLE DIS: when this option is set at ON, the title of the presets can be displayed on the left of the screen when the preset is called, such as “NO.001 ABCDEFGH”. If no title is set, then only “NO. 001” is displayed. The modification of the title of the preset is set on the PROGRAM option.

TITLE POS: to set the display location of the title of the preset, which can be from Line 1 to Line 10. The Line 1 is on the top of the screen.

CAM DISPLAY: when this option is set at ON, the display screen of the camera can be displayed.

RETURN: to exit the main menu.

DISPLAY SETUP		
1.	ID DISPLAY	ON
2.	ID POS	TOP-L
3.	TITLE DIS	ON
4.	TITLE POS	01 LINE
5.	CAM DISPLAY	ON
6.	RETURN	

Camera Setup

SLOW SHUTTER: Slow Shutter function with Man/Auto options.

When the option be AUTO, ASS shall be displayed on the monitor.

BACK LIGHT: Backlight Compensation ON/OFF.

ICR SHOT: Low Illumination, ON - open/AUTO - automatic.

IRIS: Automatic Exposure, AUTO - automatic/MANU - manual.

D-ZOOM: Digital Zoom, ON - open/OFF - close.

FOCUS: Automatic focusing, AUTO - automatic/MANU - manual.

WB SET: White Balance, ATW /INDOOR /OUTDOOR /ONEPUSH /AUTO /MANU

MENU OF CAM: this option is empty.

RETURN: return to the main menu.

CAMERA SETUP	
1.SLOWSHUTTER	AUTO
2.BACK LIGHT	OFF
3.ICR SHOT	AUTO
4.IRIS	AUTO
5.D-ZOOM	ON
6.FOCUS	AUTO
7.WB SET	ATW
8.MENU OF CAM	
9.RETURN	

Control Setup

WIPER: rain wiper control.

DEFROSTER: defroster control.

RESERVED AUX: auxiliary switch control.

ALARM1: external alarm 1 control.

LINKAGE1: set linkage with external alarm 1.

ALARM2: external alarm 2 control.

LINKAGE2: set linkage with external alarm 2.

HOME OPTION: enter the submenu of automatic home function.

CONTROL SETUP	
1.WIPER	OFF
2.DEFROSTER	OFF
3.RESERVED AUX	OFF
4.ALARM1	ON
5.LINKAGE1	50
6.ALARM2	ON
7.LINKAGE2	49
8.HOME OPTION	
9.RETURN	

AUTO HOME: when this option is set at ON, home position function is opened. This means the PT shall return home position if user has no any action in a period of time. The PT cannot return home position automatically if it is under the patrol state. If no home returning is needed under the stop state, please set this option at OFF.

HOME POS: set home position. HOME POS can be sat from preset 1 to preset 63, or preset 65 to preset 128.

DWELL TIME: set the time for home position, which means the PT shall go to home position if no any control occurs within the set time from 1 to 99 minutes.

RETURN: return to the menu one level up.

RETURN: return to the main menu.

HOME OPTION	
1.AUTO HOME	ON
2.HOME POS	01
3.DWELL TIME	05 MIN
4.RETURN	

Program

AUTO PAN START POS: to set the start point of the AutoPan. After entering, move the PT by the joystick. Push CLOSE button to save the current position and return.

AUTO PAN END POS: to set the end point of the AutoPan. After entering, move the PT by the joystick. Push CLOSE button to store the current position and return.

RUN AUTO PAN: to run the AutoPan. Please set the start point and the end point first. If the start position and the end position is the same position, the PT shall make 360°AutoPan. The speed of the AutoPan is divided into six grades: FAST/NORMAL/SLOW/

PROGRAM	
1.AUTO PAN START POS	
2.AUTO PAN END POS	
3.RUN AUTO PAN	SLOW
4.SET TITLE	01
5.SET PATROL	01
6.RUN PATROL	01
7.RECORD PATTERN	
8.RUN PATTERN	
9.RETURN	

-FAST/-NORMAL/-SLOW. The first three grades are the AutoPan less than 180° while the latter three grades are the AutoPan larger than 180°. The speed can be adjusted by PAN LEFT/PAN RIGHT. Push OPEN button to run and exit the menu. The start point and the end point are set from options 1 and 2 on this menu.

SET TITLE: to edit the titles of preset. Only first 63 presets may have their titles and the preset number can be selected by PAN LEFT/PAN RIGHT. Press OPEN button to enter into the edit state and press CLOSE button to exit the edit state. Operations under the edit state can be seen thereafter.

SET PATROL: to edit patrol data. Select the number of patrol by PAN LEFT/PAN RIGHT. Press OPEN button to enter into the edit state and press CLOSE button to exit the edit state. Operations under the edit state can be seen thereafter.

RUN PATROL: to run patrol function. Select the number of patrol by PAN LEFT/PAN RIGHT. Press OPEN button to run and exit the menu.

RECORD PATTERN: to recode pattern. It can remember PTZ operation for 40 seconds. Complete the edit when 40 seconds are up or push CLOSE button.

RUN PATTERN: to playback pattern. You can also control the joystick to stop running.

RETURN: return to the main menu.

3. Appendix of the Manu

Operation of Patrol under the Edit State

After entering into the edit state, the screen shows as follows:

NO	POS	SP	TM	POS	SP	TM
01	001	01	01	002	01	01
03	003	01	01	004	01	01
05	---	---	---	---	---	---
07	---	---	---	---	---	---
09	---	---	---	---	---	---
11	---	---	---	---	---	---
13	---	---	---	---	---	---
15	---	---	---	---	---	---

SEQ: 01 CLOSE: EXIT

NO – serial number of patrol
 POS – number of preset
 SP – leaving speed
 TM – dwelling time

Enter into edit state, display on screen is as follows:
 Edit Area, one line shows data of two point .

SEQ: 01 – it means current set patrol 1
 CLOE: EXIT – push CLOSE to exit edit state

The top line and the bottom line display prompt message, and the middle area displays information of each locus, **one line shows data of two points**. Move the cursor by PAN LEFT/RIGHT and modify data by TILT UP/DOWN. Press the button down for 1 second to accelerate. Press CLOSE button to exit the edit state and store modification. In above figure, the program stores four patrol points. The settable range of POS is from 1 to 63 or 65 to 128. In case POS is “---“, it means the skip this point. The settable range of SP is from 0 to 8 (0 and 1 are same at the highest speed while grade 8 has the lowest speed). The settable rage of TM is from 0 to 99 seconds.

Operation of the Title of Preset under Edit State

After entering into the edit state, the screen show as the drawing.

You can find current setup is the preset 1 with the title “NO TITLE”. Move the cursor by PAN LEFT/RIGHT and modify data by TILT UP/DOWN. Press the button down for 1 second to accelerate. Press CLOSE button to exit the edit state and save modification. The title of preset can contain 8 characters such as

0~9, A~Z, +, - and blank. Note: the first letter should be 0~9 or A~Z otherwise it means to delete the title of the presets and it shall only show “NO.XXX” without the title when preset points.

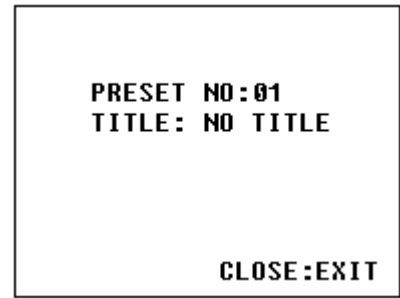

V Special Operation

The preset 51 to 60 are used for special functions. It has special meanings to set or call these points. Therefore these points should not be used in functions of automatic operation of the pan/tilt such as multiple points patrol, external alarm linkage etc. so as to avoid error actions.

Preset	Set Preset	Call Preset
51	Wiper ON	Wiper OFF
52	Defroster ON	Defroster OFF
53	Auxiliary Output AC24V ON	Auxiliary Output AC24V OFF
54	Linkage of External Alarm 1 ON	Linkage of External Alarm 1 OFF
55	Linkage of External Alarm 2 ON	Linkage of External Alarm 2 OFF
56	Reserved	Reserved
57	Reserved	Reserved
58	Reserved	Reserved
59	Reserved	Reserved
60	Reserved	Reserved

VI Technical Data

Specifications	Image Inductor	1/4" Color CCD
	Effective Pixels	752H×582V (440000pixels) PAL
	Synchronous System	External synchronous
	Video Output	VBS 1.0Vp-p/75 Ω
	White Balance	Automatic/Manual
	Power Supply	AC220V/110V/24V
	Power Consumption	70W
	Weight	13Kg
	Relative Humidity	10-75% (in case no condensation)
	Operation Temperature	-35°C ~ +55°C
Camera Function	Scan System	15.625KHz (H) 50Hz (V)
	Horizontal Resolution	480 lines
	Signal/Noise Ratio	Larger than 48db
	Electronic Shutter	1/3~1/10000 seconds
	Lowest Illumination	0.01~1Lux (F1.6) (determined by different model of camera)
Parameters of Lens	Zoom rate	x16、 x18、 x22、 x23、 x25 optical zoom and x4 electronic zoom (determined by different model of camera)
	Iris	Automatic/Manual
	Focus	Automatic/Manual